

2 Mile Industrial Lantern

World class engineering for the ultimate in efficiency and reliability. The MuSolar T82e leaves its competition behind with proprietary ultra-efficient optics, an Advanced Charge Management System, and Adaptive Power Control. It is also available with optional GPS synchronization.



THE T82e ADVANTAGE

- Enhanced marine safety at minimal cost
- Easy installation - just bolt lantern down
- Proprietary optics produce best in class beam quality
- Lightweight design - fits on small structures
- Proven reliability with outstanding performance
- Easy in service battery replacement

Ordering Information

	T82A - xxxFC	Amber Lantern	(xxx = flash code)
	T82R - xxxFC	Red Lantern	(xxx = flash code)
	T82G - xxxFC	Green Lantern	(xxx = flash code)
	T82W - xxxFC	White Lantern	(xxx = flash code)
	T82B - xxxFC	Blue Lantern	(xxx = flash code)

Accessories

PGM256e Programmer	Universal Flash Code Programmer
T82 - BD	Stainless Steel Bird Deterrent
T82 - 5000B	Replacement Battery Pack
T8x - GPS	GPS Sync Module

This equipment complies with requirements of the U.S. Coast Guard in 33 CFR part 66.

Industrial Lantern

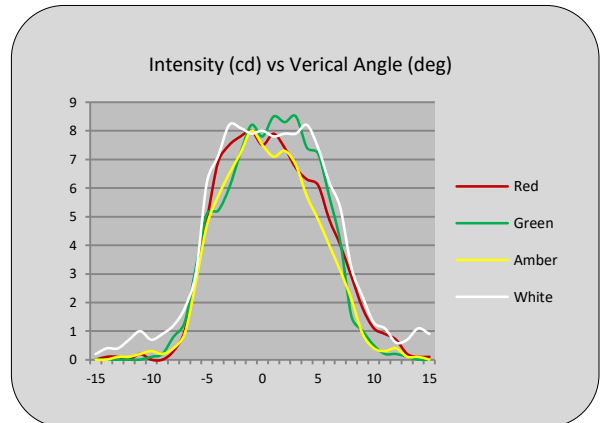
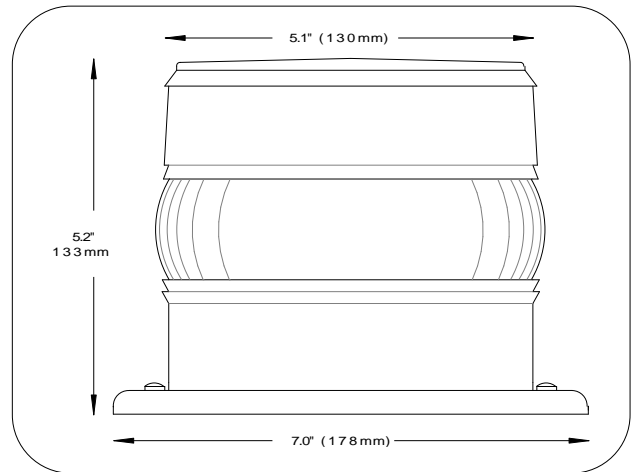
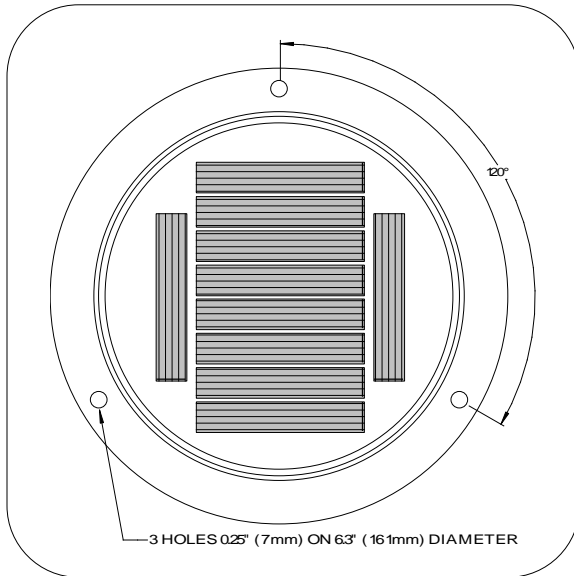

SPECIFICATIONS

Colors: Amber, Red, Green, White, and Blue

Flash Patterns: 255 IALA flash patterns or user defined pattern

Light Source: 5/10 elliptically focused high intensity LEDs

Optical Rating: 5 candela minimum / 10 degrees vertical divergence

Expected Service Life: 15 years (Battery replacement every 5 years)

Materials: UV-Stabilized Lexan® Polycarbonate, 18-8 Stainless hardware

Temperature Range: -25° to +70° Celsius (-15° to 150° Fahrenheit)

Physical: 840 grams (1.14 lb), IP68 rated

Warranty: Full 3 years

FOR MORE INFORMATION CONTACT: