

5 Mile Industrial Lantern

MuSolar presents an industry first. A compact self contained solar powered lantern designed not only to be serviceable but fully upgradable. Built on a durable triple hardcoat anodized aluminum base the MuSolar T85e leaves its competition behind. Next gen optics, electronics, and mechanics make this lantern the last one you'll ever need.

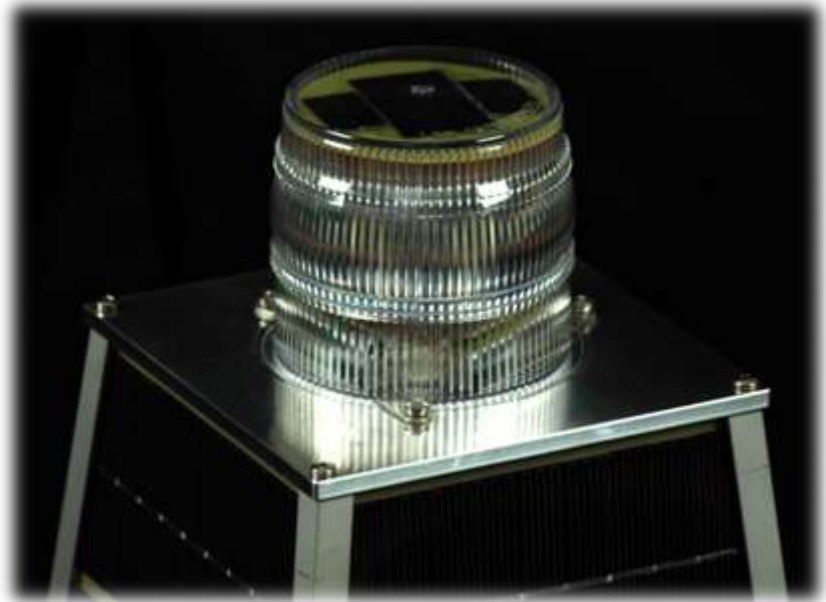

THE T85e ADVANTAGE

- Fully serviceable/upgradeable
- Proven reliability with outstanding performance
- Easy installation - just bolt lantern down
- Lightweight design - fits on small structures
- Proprietary optics produce best in class beam quality
- Optional GPS Synchronization
- Enhanced marine safety at minimal cost

Ordering Information

	T85A - xxxFC	Amber Lantern	(xxx = flash code)
	T85R - xxxFC	Red Lantern	(xxx = flash code)
	T85G - xxxFC	Green Lantern	(xxx = flash code)
	T85W - xxxFC	White Lantern	(xxx = flash code)
	T85B - xxxFC	Blue Lantern	(xxx = flash code)

Accessories

PGM256e Programmer	Universal Flash Code Programmer
T85 - BD	Stainless Steel Bird Deterrent
T85 - 10KB	Replacement Battery Pack
T8x - GPS	GPS Sync Module

This equipment complies with requirements of the U.S. Coast Guard in 33 CFR part 66.

Industrial Lantern

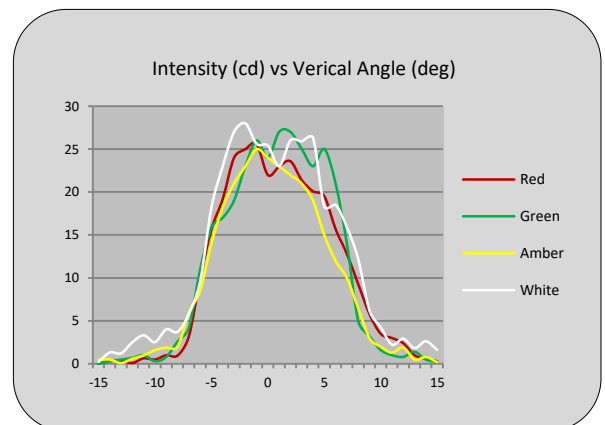
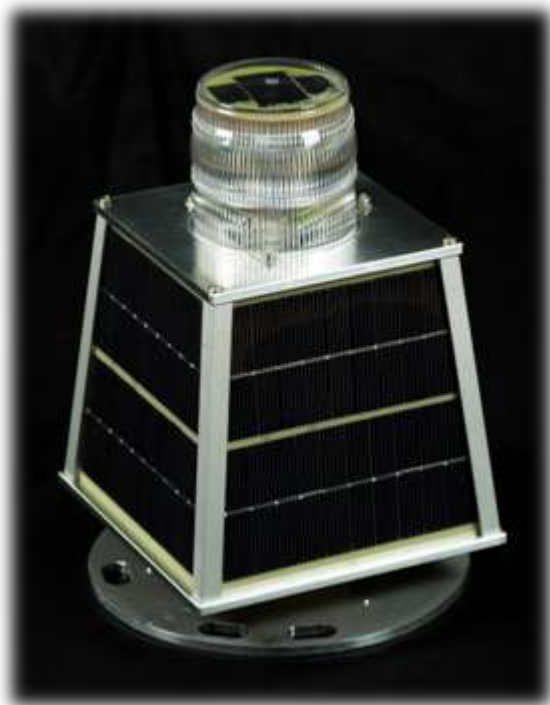
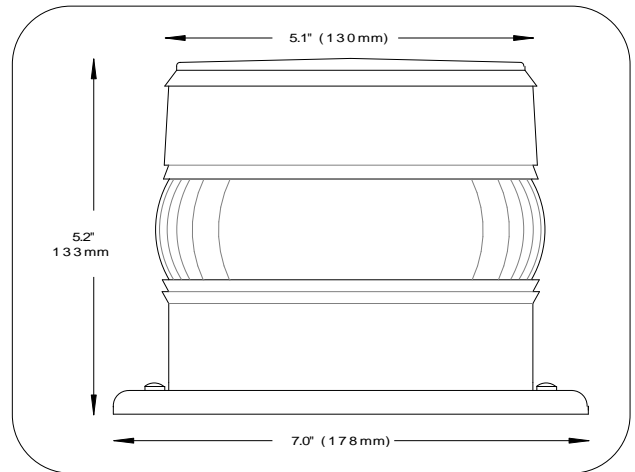
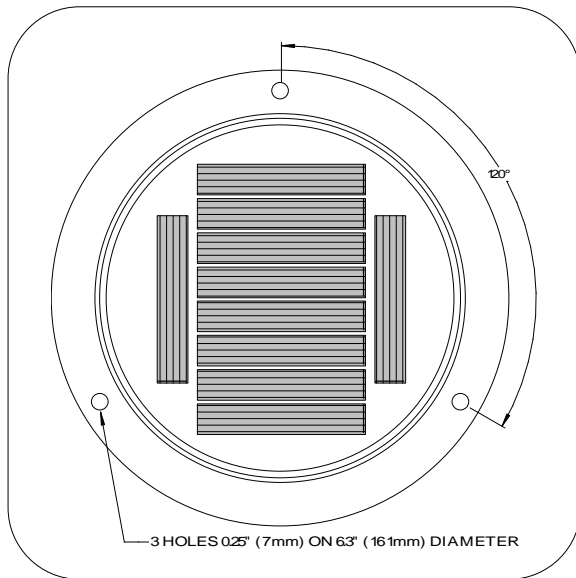

FOR MORE INFORMATION CONTACT:

SPECIFICATIONS

Colors: Amber, Red, Green, White, and Blue

Flash Patterns: 255 IALA flash patterns or user defined pattern

Light Source: 10 elliptically focused high intensity LEDs

Optical Rating: 15 candela minimum / 10 degrees vertical divergence

Expected Service Life: 25 years (Battery replacement every 5 years)

Materials: UV-Stabilized Lexan® Polycarbonate, Hardcoat Anodized T6061 Aluminum, 18-8 Stainless hardware

Temperature Range: -25° to +70° Celsius (-15° to 150° Fahrenheit)

Physical: 1.29Kg (2.14 lb), IP68 rated

Warranty: Full 5 years